

Sound Anchors Fixed Start Motorized Stand Instructions



Sound Anchors
2835 Kirby Circle NE Unit # 110
Palm Bay, FL 32905
(321) 724-1237
Email: info@soundanchors.com
www.soundanchors.com

Thank you for purchasing Sound Anchors Fixed Start Motorized speaker stands. Motorized speaker stands allow you to easily adjust the height of your studio monitors or speakers with precision. This feature is particularly useful for optimizing the listening position, ensuring that the sound reaches your ears at the desired level. With motorized controls, you can raise or lower your speakers at the touch of a button. This eliminates the need for manual adjustment or using tools, saving you time and effort during setup or when experimenting with different speaker placements. Since many different sizes of people work in the studio, by having the ability to adjust the height of your speakers effortlessly, you can achieve better ergonomic positioning in your studio environment.

Speaker positioning plays a crucial role in achieving optimal sound quality and imaging. Motorized stands allow you to fine-tune the speaker placement, ensuring accurate stereo imaging, proper soundstage, and minimizing undesirable acoustic effects such as phase cancellation or reflections. Motorized stands offer flexibility in adapting to different scenarios. You can quickly adjust the height to accommodate standing or seated positions, change the speaker height to match different studio setups, or even lower them for easier storage or transportation.

Hardware Inventory

- 4 ea. Black & Bluedots
- 4 ea. M6 x 20 button head socket cap screw
- 4 ea. 1/4 flat washer
- 4 ea. M6 X 20 flat head socket cap screw
- 4 ea. 3/8 in. flat washer
- 4 ea. 3/8-16 jam nut
- 4 ea. 3/8-16 spikes

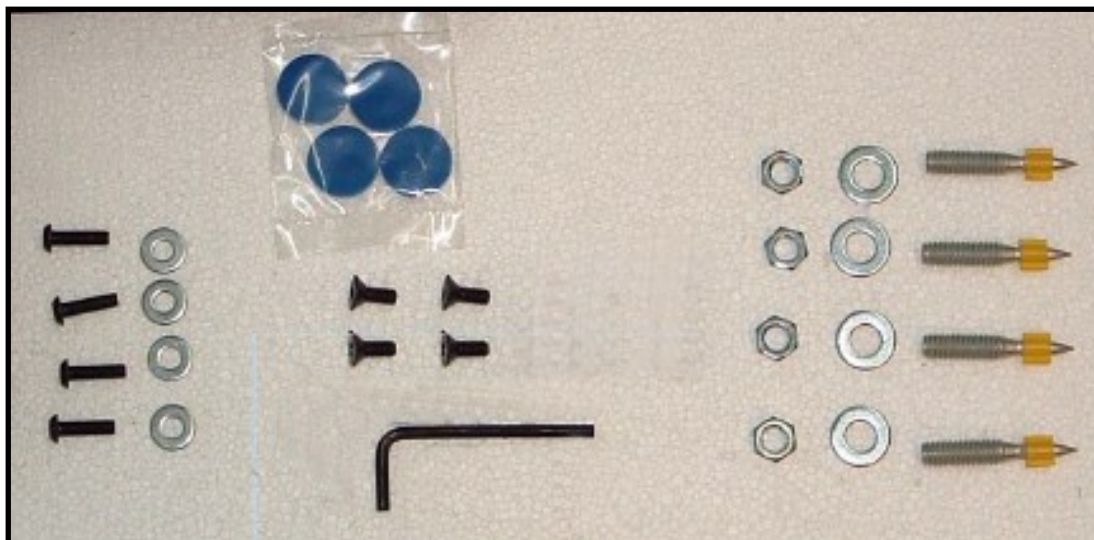

Stand Parts

- 1 Base Weldment
- 1 Speaker Platform

Electrical Parts

- 1 Lift Motor
- 1 Control Box (may be shared)
- 1 Remote Switch (1 per Control Box)
- 1 Motor Control Cable (1 per Motor)
- 1 Power Cable (1 per Control Box)



Tools

- 3/16" Hex Key

Assembly Instructions

1. Install one spike into each insert on the bottom of the stand so that about 1/2" of thread is left protruding from the stand.
2. Install washers and jam nuts (***Finger tighten jam nuts — use no tools.***)
3. Place stand in the intended use location.
4. Level the stand using the spikes so that the upright is perpendicular to the floor.
5. Tighten jam nuts using a 9/16" wrench.

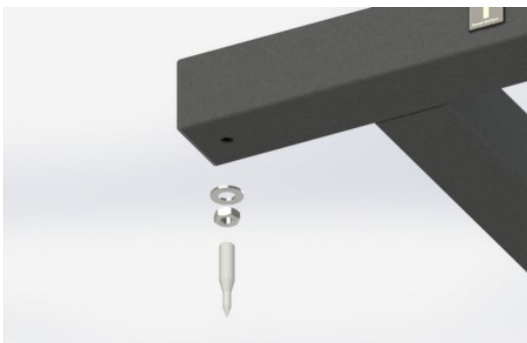

Motor Installation

1. Position the motors as shown on Page 5 of these instructions so that the four holes on the motor mounting tabs line up with the four M6 threaded holes in the motor base.
2. Fasten the stand base to the motor base using four M6 X 20 button head socket cap screws with the 1/4" flat washers. **Finger tighten only.**
3. Tighten the screws with the provided hex wrench until they are just snug. **Take care to not overtighten.**

Installing the Speaker Platforms

1. Fasten the speaker platform to the motor lift using four M6 X 20 flathead socket cap screws.

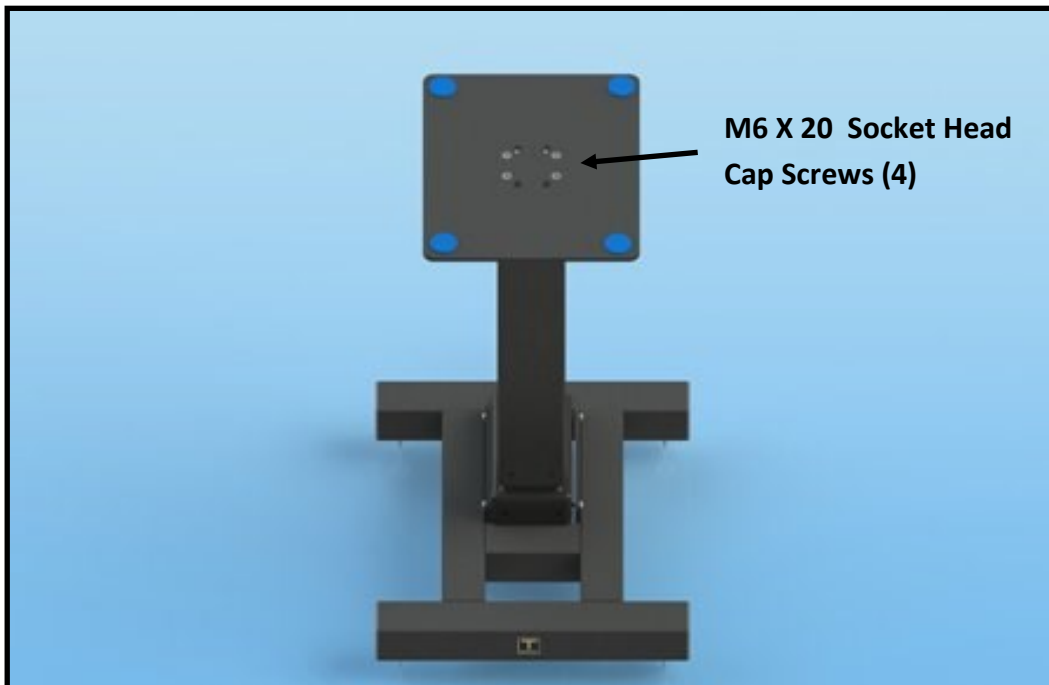

Putting your Stands in Motion

1. Connect all wiring as shown on the diagram on Page 6. Note if you have more than one motor all motors must be connected before powering up or none will work.
2. After everything is connected together and plugged in, hold the down button for 45 seconds. This is an initial start procedure that syncs the motor with the controller.
3. Remove the plastic film from the blue side of the black and blue dots and place blue side on the platform. The speaker should rest on the black side of the Sorbothane pad. Place one black and blue dot on each corner of the speaker platform.
4. Place the speaker on top of the platform. Take care that the speaker baffle is forward of the front edge of the speaker platform so that there are no edge diffractions.
5. You might need to adjust the platform height in order to get the desired start height.

Important Black & Blue Dot Guidelines

Sound Anchors' Black & Blue Dots are made of urethane coated Sorbothane. Sorbothane is unique in that it absorbs motion in all directions making it an ideal isolation material between speakers and stands. Black & Blue Dots do not have adhesive on them. The blue side should be placed on the stand and the black side should be placed under the speaker. However, under the weight of the speaker and over time they will compress and become gummy and possibly discolor or mar the finish on the bottom of the speaker. Under certain conditions they may also adhere to the bottom of your speakers, causing difficulty in removing or repositioning the speaker. The urethane coating has been added to help alleviate this issue.

Care should be used when removing speakers from the stands as to avoid damaging the bottom of the speaker. It is recommended that a thin blade (i.e. putty knife) be slid in between the speaker and the platform to break the adhesion and dislodge the Black & Blue Dot. Black & Blue dots should not be used on speakers with a lacquer finish. These surfaces are highly susceptible to marring from use of the Black & Blue dots.

Moto-F

Fixed Start Motorized Stand Assembly

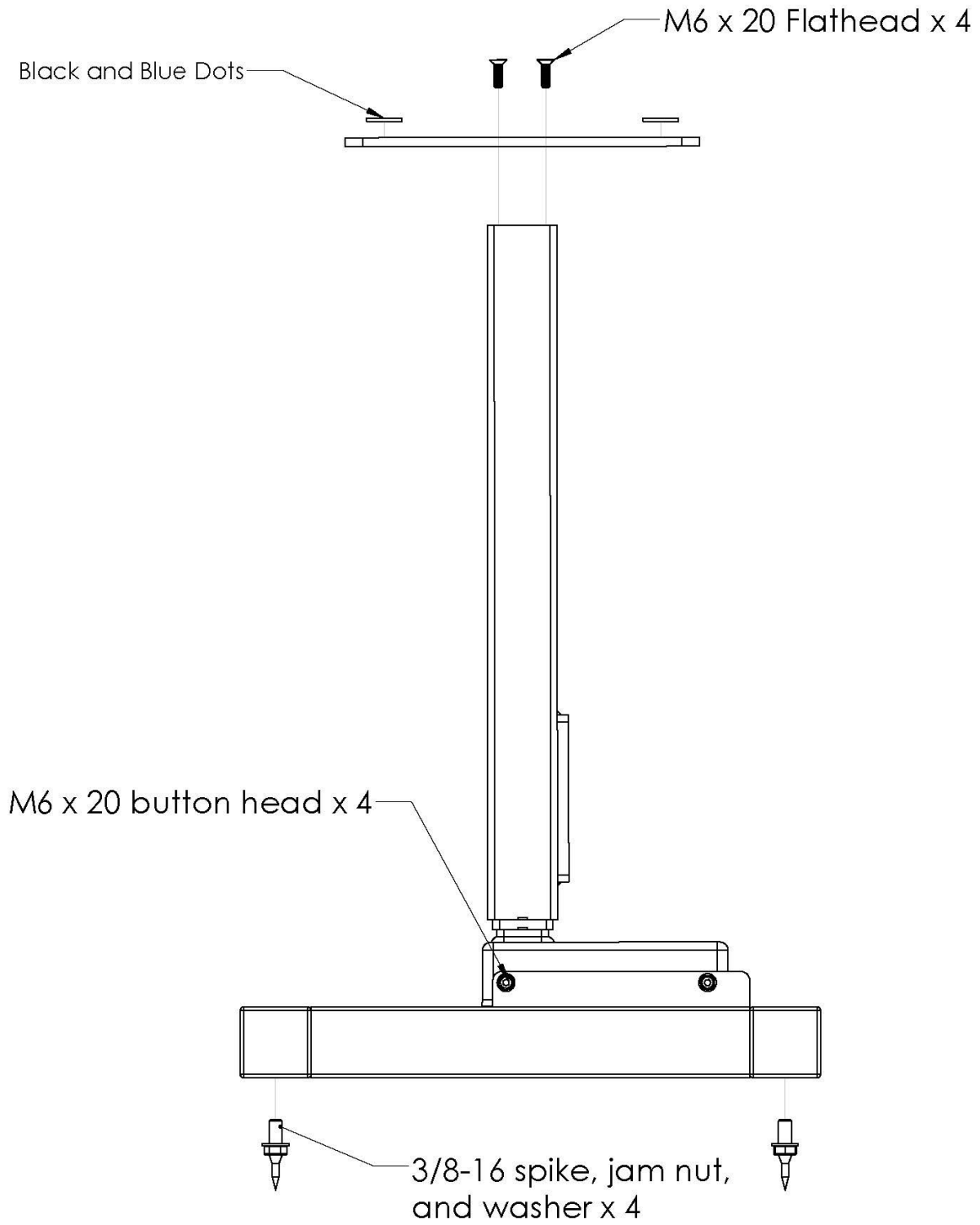

**Sound Anchors Motorized
Fixed Start Wiring Diagram**

