

Sound Anchors Motorized (MOTOA) ADMID Instructions



Sound Anchors
2835 Kirby Cir NE Unit 110
Palm Bay, FL 32905
321-724-1237

Office@Soundanchors.com www.soundanchors.com

Sound Anchors Motorized ADMID Stands

Thank you for choosing Sound Anchors stands for your studio. Our stands can make a significant difference in studio recordings because they help ensure accurate and precise sound reproduction. Also, by providing a stable and isolated platform for the speakers, our stands can help reduce unwanted resonance and distortion, improve imaging and bass response, and create a cleaner, clearer sound.

Hardware List



Hardware Inventory:

- 4 ea. 3/8-16 Jam Nuts
- 4 ea. 3/8 Flat Washers
- 4 ea. 3/8-16 spikes
- 4 ea. Black & Blue Dots
(not pictured)
- 4 ea. 3/8-16 x 3/4 Low Head
Socket Head Cap Screws
- 4 ea. 7/16-14 x 3/4 Hex Head
Cap Screws (gold)
- 4 ea. 7/16-14 x 1 Flat Head
Cap Screws
- 4 ea. M8-1.25 x 20 Socket
Head Cap Screws
- 4 ea. M8 Washers
- 4 ea. 5/16-18 x 3/4 Socket
Head Cap Screws
- 8 ea. M6-1 x 20 Button Head
Cap Screw
- 8 ea. M6 flat washers
- 1/4" Hex Wrench
- 3/8" Hex Wrench
- 3/16" Hex Wrench

Sound Anchors Motorized ADMID Parts List

- 1) 2 ea. MOTO ADMID FEET
- 2) 1 ea. Lower Cross Member
- 3) 1 ea. Upper Cross Member
- 4) 2 ea. Speaker Support Bars
- 5) 2 ea. Lift Column Cradles
- 6) 2 ea. Height Risers (Note: height can vary. Short risers may be pre-installed into ADMID feet –part 1.)

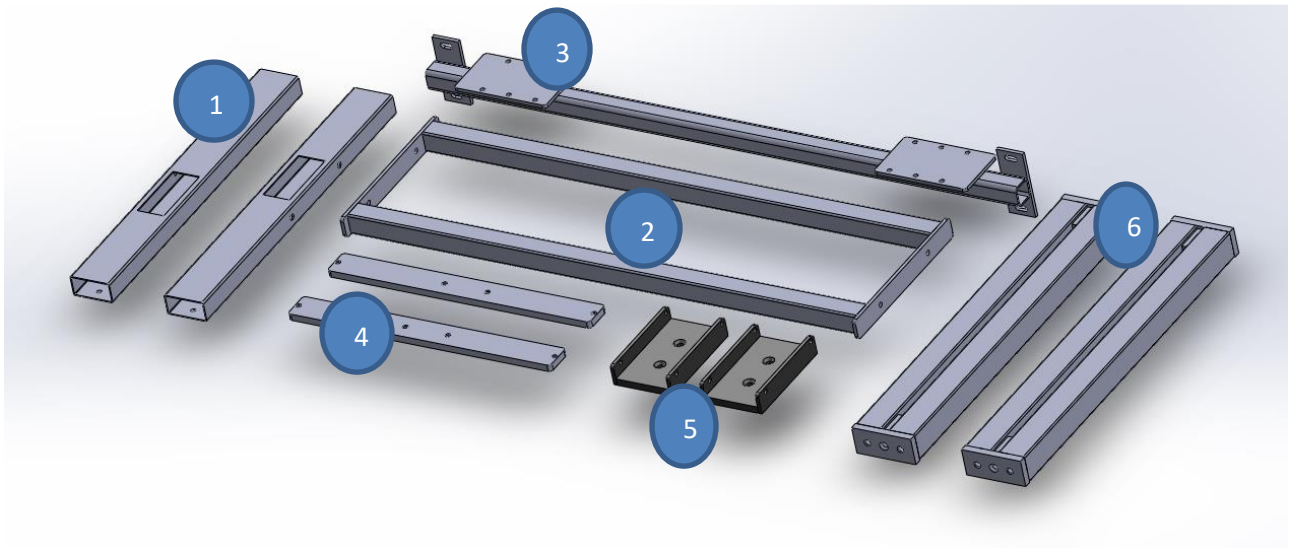

The parts shown are the Sound Anchors manufactured parts for the Motorized ADMID stand. We will also supply electrical components from Linak as part of the assembly.

Assembly

1. Assemble the spike, jam nut, and washer by threading the nut onto the spike until it is set at the end of the threads of the spike. Place the washer on top of the nut and screw the spikes onto the feet of the stand. Make sure they are hand tight. When the stand is fully assembled, adjustments can be made to the spikes to level out the stand.

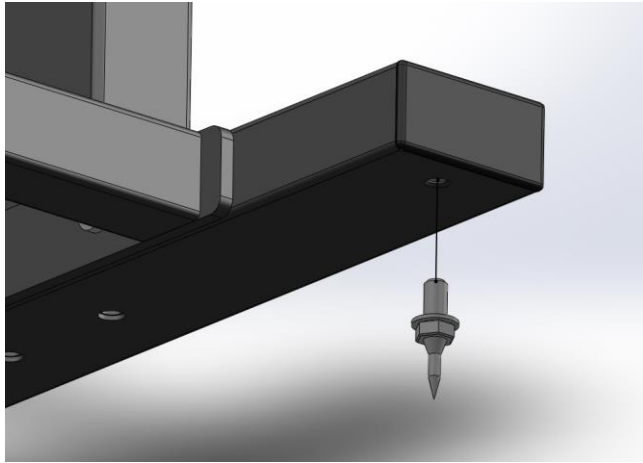

2. Fasten the 2 Feet to the lower cross piece with the 3/8-16 x 3/4 Low Head Socket Cap Screws.

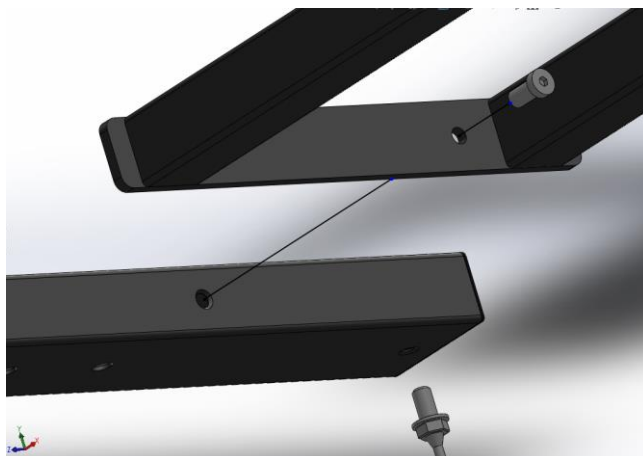

3. Fasten the upright risers to the lower cross assembly by fitting the risers into the pocketed hole in the top of each foot. Ensure the riser is seated all the way down into the foot. Fasten them together with the 7/16-14 x $\frac{3}{4}$ Hex Head Screw (Gold).

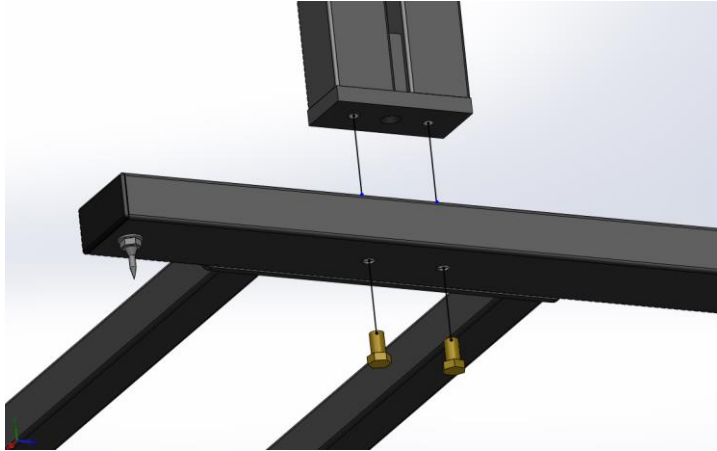

4. Fasten a Motor Cradle to the top of each riser by using the 7/16-14 x 1 Flat Head Cap Screws. Ensure the holes specified in the drawing are oriented toward the back of the stand to ensure the motor can be mounted properly.

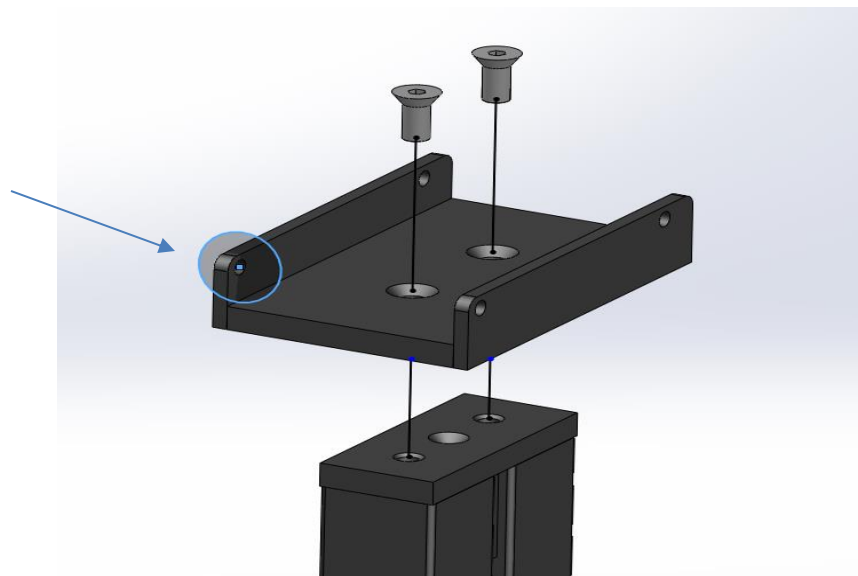

5. Attach the Motorized Lift Columns to the motor cradles by fastening them with the M6 button head screws and M6 flat washers.

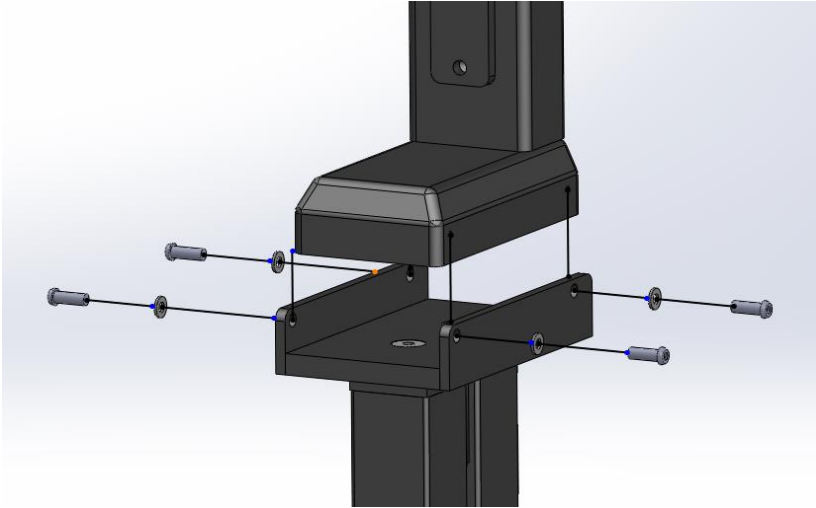

6. Attach the upper cross piece to both motors using the M8 socket head cap screws with M8 washers. There may be a need to pull the uprights together toward the center to ensure the crosspiece fits on the stand.

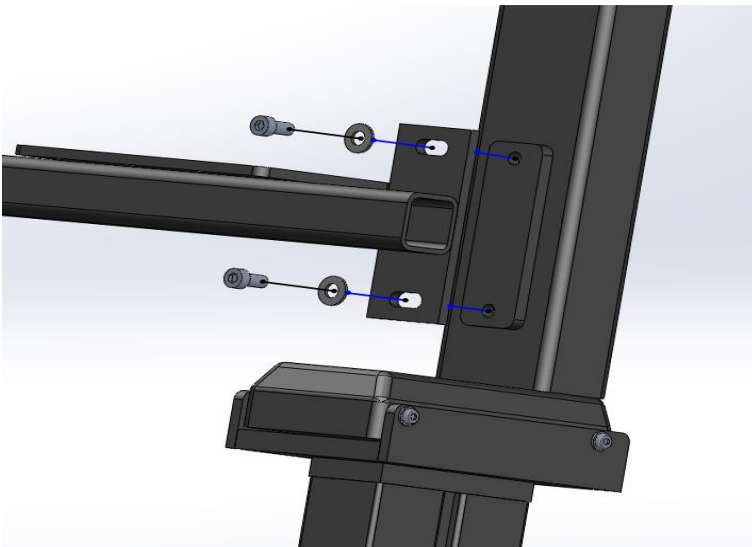

7. Attach the support bars to the upper cross piece by fastening the 5/16-18 x 3/4 Socket Head Cap Screws through the bottom of the crosspiece plates. The screws will thread into the support bar from below.

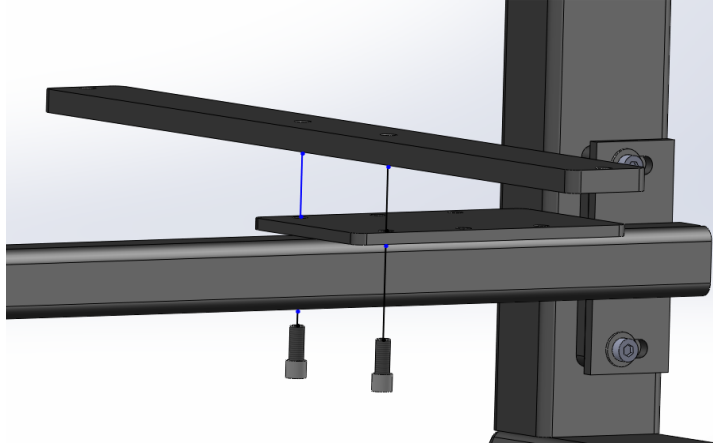

8. Attaching the 5/16-18 x 1/2 Socket Head Cap Screw to the rear hole of the support bar is optional. This screw is intended to function as a stop for speakers on our normal ADMID stands when they are tilted back. The Moto ADMID stand is not designed for tilting, but if the user chooses to adjust the spikes at the base of the stand for a slight tilt, adding these bolts to the support bar would be necessary.

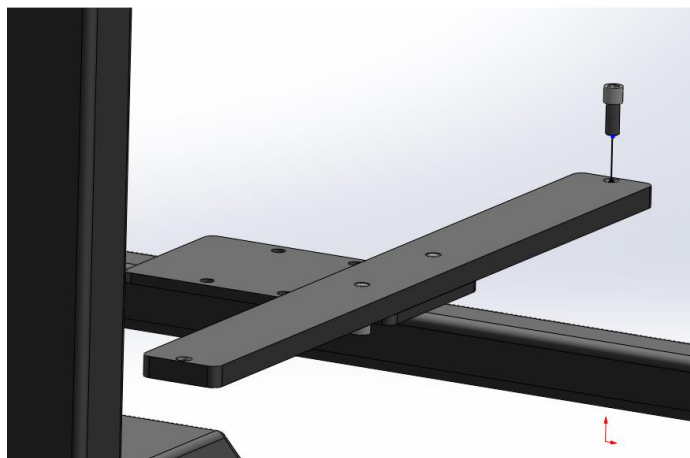

9. Lastly, tighten down any bolts left loose for fitment. Leveling should be done at this point. Add the Black & Bluedots to each end of each support bar and place your speaker on top. The Speaker should appear to be centered on the stand when you look at it from the front or the side. Keeping the center of gravity within the footprint of the stand will maximize stability and performance.

Important Black & Blue Dot Guidelines

Sound Anchors' Black & Blue Dots are made of urethane coated Sorbothane. Sorbothane is unique in that it absorbs motion in all directions making it an ideal isolation material between speakers and stands. Black & Blue Dots do not have adhesive on them. The blue side should be placed on the stand and the black side should be placed under the speaker. However, under the weight of the speaker and over time they will compress and become gummy and possibly discolor or mar the finish on the bottom of the speaker. Under certain conditions they may also adhere to the bottom of your speakers, causing difficulty in removing or repositioning the speaker. The urethane coating has been added to help alleviate this issue.

Care should be used when removing speakers from the stands as to avoid damaging the bottom of the speaker. It is recommended that a thin blade (i.e. putty knife) be slid in between the speaker and the platform to break the adhesion and dislodge the Black & Blue Dot. Black & Blue dots should not be used on speakers with a lacquer finish. These surfaces are highly susceptible to marring from use of the Black & Blue dots.

MOTOA ADMID Stand

The Motorized ADMID stand is one of our newest designs. It takes the adjustability of our ADMID stand and combines it with the ease and convenience of the Motorized stands. There is a bit more assembly required, but if you have a center channel speaker that needs to be moved out of the way in some applications, or speakers that need to be used in multiple locations, this is the stand for you!

If you have any questions about the stands, or any feedback, please contact Sound Anchors at (321) 724-1237. You can also email us at info@soundanchors.com.