

Sound Anchors Compact ADJ Instructions



Sound Anchors
2835 Kirby Cir NE Unit 110
Palm Bay, FL 32905
321-724-1237

Office@soundanchors.com

www.soundanchors.com

Sound Anchors Compact Adjustable Speaker Stands

Thank you for choosing Sound Anchors stands for your studio. Our speaker stands are specifically designed to provide a stable and sturdy platform for your speakers, ensuring the most accurate and high-quality sound possible. Our height-adjustable design allows you to position your speakers at the perfect height for your listening environment, guaranteeing that your sound is directed towards your ears and not the floor or ceiling. Please take the time to carefully read these instructions before assembling your stands.

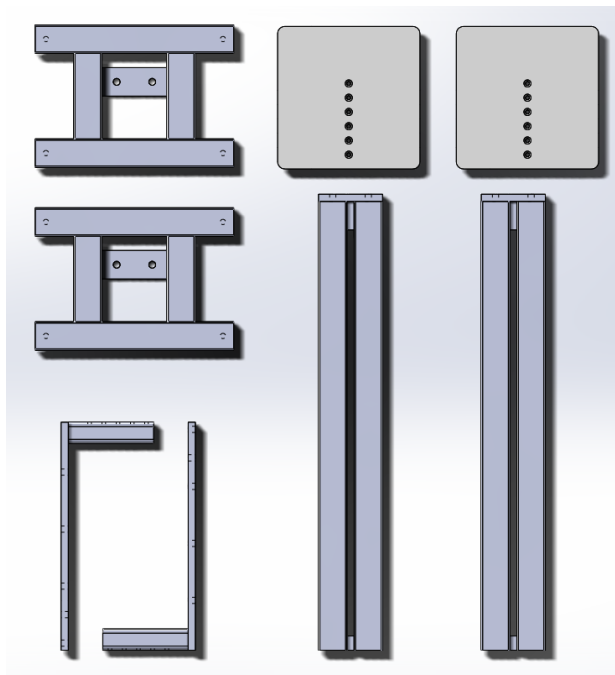

Hardware Inventory:

- 8 ea. – 3/8-16 spikes
- 8 ea. – 3/8-16 jam nuts
- 8 ea. – 3/8 flat washers
- 8 ea. – Black & Blue Dots
- 4 ea. – 1/4-20 x 5/8 Flat Head Screws
- 4 ea. – 7/16-14 x 1 Flat Head Screws
- 4 ea. – 7/16-14 x 2.5 Socket Head Screws
- 4 ea. – 7/16 Black Hardened Washers
- 1 ea. – 5/32 Hex wrench
- 1 ea. – 1/4 Hex Wrench
- 1 ea. – 3/8 Hex Wrench

Compact ADJ Parts List

- 2 ea. – Comp ADJ Bases
- 2 ea. – 32" Uprights
- 2 ea. – 10 x 10 Platforms
- 2 ea. – "L" Shaped mounting Arm

Assembly

1. Fasten the base to the upright using 2 ea. 7/16-14 x 1 Flat Head Screws, as shown in Figure 1.

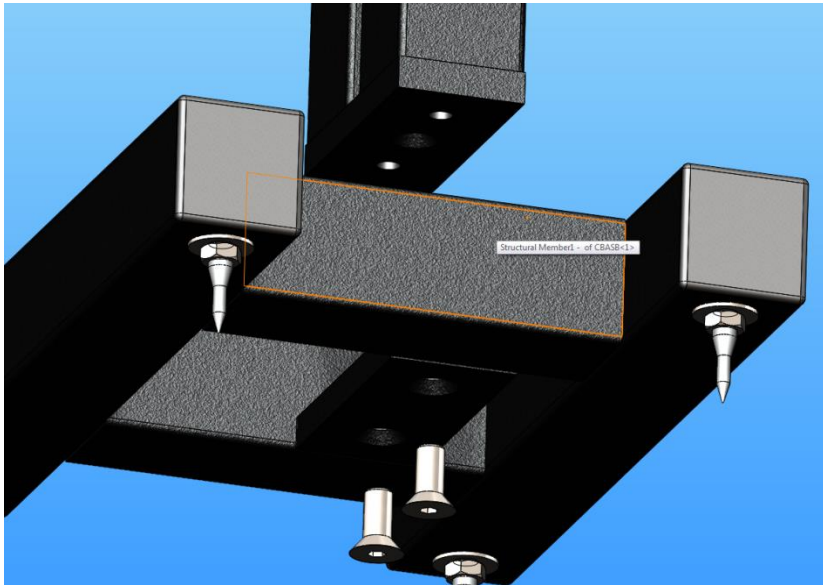

Figure 1

2. Install spikes, washers, and jam nuts into the four threaded holes in the stands base. Insert the spikes so that there are 1 or 2 threads visible after the jam nuts are set. **Jam nuts should be finger tightened only – no tools.**
3. To fasten the "L" Shape Arm to the upright, use 2 ea. 7/16-14 x 2.5 Socket Head bolts and 2 ea. 7/16 Black Hardened washers, as shown in Figure 2 (see next page). The screws will be inserted from the front of the stand and threaded into the mounting arm that is mounting to the back of the upright. This will orient the above arm over the upright giving a centered position on the stand.

Assembly (Cont.)



Figure 2

4. After determining the location where you will be setting up your stands, it is time to adjust their level. With the stand in its operational position in the room, place a magnetic torpedo level vertically on the front face on the upright. When the stand is level, tighten the jam nuts with a 9/16 wrench.
5. Adjust the platforms to the desired height.
6. Remove protective coating from the blue side of the Black & Blue dots. Place the blue side on the platform and the speaker should be placed on the black side of the Sorbothane pad. Place one Black & Blue dot on each corner of the platform.
7. Place the speaker on the platform centered with the stand.

Important Blue Dot Guidelines

Sound Anchors' Blue Dots are made of Sorbothane. Sorbothane is unique in that it absorbs motion in all directions making it an ideal isolation material between speakers and stands. Blue Dots do not have adhesive on them. However, under the weight of the speaker and over time they will compress and become gummy and possibly discolor or mar the finish on the bottom of the speaker. Under certain conditions they may also adhere to the bottom of your speakers, causing difficulty in removing or repositioning the speaker. Care should be used when removing speakers from the stands as to avoid damaging the bottom of the speaker. It is recommended that a thin blade (i.e. putty knife) be slid in between the speaker and the platform to break the adhesion and dislodge the blue dot. Blue dots should not be used on speakers with a lacquer finish. These surfaces are highly susceptible to marring from use of the blue dots.

Compact Adjustable Stand

Real estate behind your console is a key factor in figuring out the placement of equipment in your studio. The Compact Adjustable stand gives you a smaller footprint with the center mounted style, as opposed to the cantilevered design of the normal ADJ stands. With this, it is much easier to fit a pair of speakers in your workspace to maximize the performance and get the desired result from your work. The Compact Adjustable is made from the same rigid material as our tried and tested ADJ1 and ADJ2 stands. You do lose some of the adjustability range, but if you know the desired height within 3 or 4 inches, this stand will work wonders in your studio. You are now ready to experience the ultimate in stability, adjustability, isolation, and durability. Thank you again for choosing Sound Anchors to take your recordings to the next level.