

Sound Anchors Barefoot Studio Monitor Stand



Thank you for purchasing Sound Anchor Barefoot Monitor Stands. These stands were designed for your Barefoot MM27 speakers. They were specifically developed with the needs of the audio professional in mind. If set up properly they will deliver a high level of performance and will last for many years.



Sound Anchors
2835 Kirby Circle NE Unit #110
Palm Bay, FL. 32905 Phone: (321) 724-1237
www.soundanchors.com info@soundanchors.com

Parts List

Per Stand

- 1 ea. Barefoot Base Weldment
- 1 ea. 56" Upright
- 1 ea. Speaker Mounting Plate
- 1 ea. Speaker Mounting Tube
- 2 ea. Speaker Mounting Bars
- 2 ea. 7/16-14 x 3 Socket Head Cap Screws
- 2 ea. 7/16 Spherical Washers
- 2 ea. 7/16-14 x 3/4 Socket Head Cap Screws
- 4 ea. 3/8-16 Spikes
- 4 ea. 3/8-16 Jam Nuts
- 4 ea. 3/8 Flat Washers
- 4 ea. M8 x 35 Socket Head Cap Screw
- 4 ea. 5/16-18 x 1 1/2 Socket Head Cap Screw
- 4 ea. 5/16 Flat Washers
- 1 ea. 3/8 Hex Key
- 1 ea. 6mm Hex Key
- 1 ea. Leveling Pad
- 2 ea. 7/16-14 x 1" Flathead Socket Head Cap Screws
- 6 ea. 5/16-14 x 1 1/2" Flathead Socket Head Cap Screws
- 1 ea. 3/16 Hex Key
- 1 ea. 1/4 Hex Key

1. Install one spike, washer, and jam nut combination into each insert on the bottom of the stand so that about 1/2" of thread is left protruding from the stand. Finger tighten only (use no tools) you will tighten them when you level the stands with the spikes later.



2. Fasten the upright to the base using 2 ea. 7/16-14 x 1" long flat head socket cap screws tighten firmly.

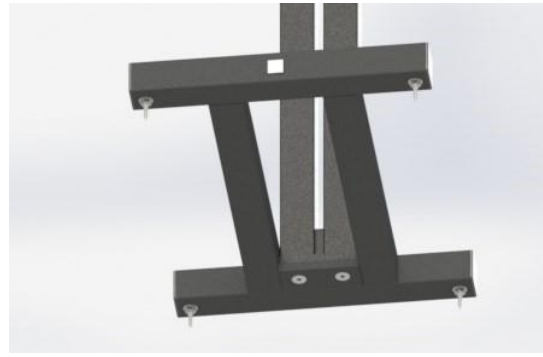
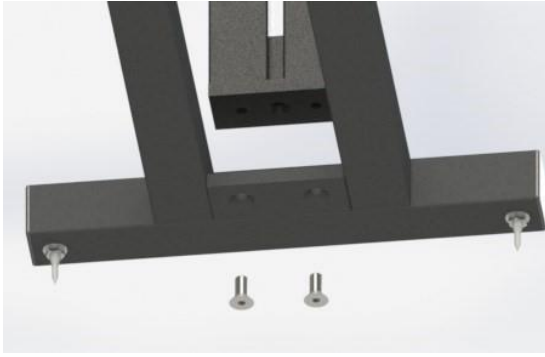

3. Assemble the speaker mount subassembly.

Item #	Description	Quantity
1	Speaker Mounting Bar	2
2	Speaker Mounting Tube	1
3	5/16-18 X 1 1/4" Long Flat Head Socket Cap Screw	4
4	Speaker Mounting Plate	1
5	Leveling Pad with 3/8-16 Threaded Stem	1
6	3/8-16 Hex Jam Nut	1
7	7/16-14 X 3/4" Long Flat Head Socket Cap Screw	2
8	5/16-18 X 1 1/2" Long Flat Head Screw	2

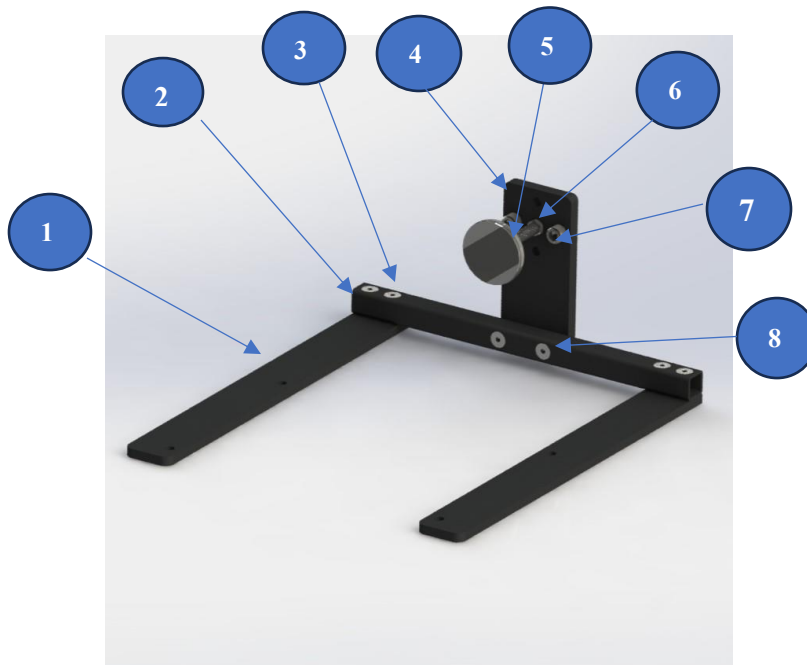

4. You have three options for assembling the speaker mounting plate.

Left plate image shows no 7/16-14 x 3/4 screws, this image is used for either horizontal or vertical speaker set-ups where no speaker tilt will be required.

Center plate image shows which holes the 7/16-14 x3/4 screws are inserted into for horizontal speaker set-ups where speaker tilt will be required.

Right plate image shows which holes the 7/16-14 x3/4 screws are inserted into, this is used for vertical speaker set-ups where speaker tilt will be required.

If you are going to require either horizontal or vertical tilt the 7/16-14 x3/4 screws must be tightened so that the ends of the screws protrude through the plate equally about 1/4" as shown in the far right image (side view).



5. Fasten speaker mounting tube to speaker mounting plate using (2 ea.) 5/16-18 x 1 1/2" Long Flat Head Socket Cap Screws. Note that the tube is countersunk on one surface, this surface is the top surface.



6. Fasten the mounting bars to the mounting tube using (4 ea.) 5/16-18 x 1 1/2" Long Flat Head Socket Cap Screws. Note that the speaker mounting bars are both positioned so that the speaker mounting holes (labeled "A") are toward the inside of the assembly. You will want to leave these screws 1/2 turn loose to help with lining up the speaker screws to the stand.

Attention: *You must remember to tighten these screws firmly before tightening the speaker mounting screws.*

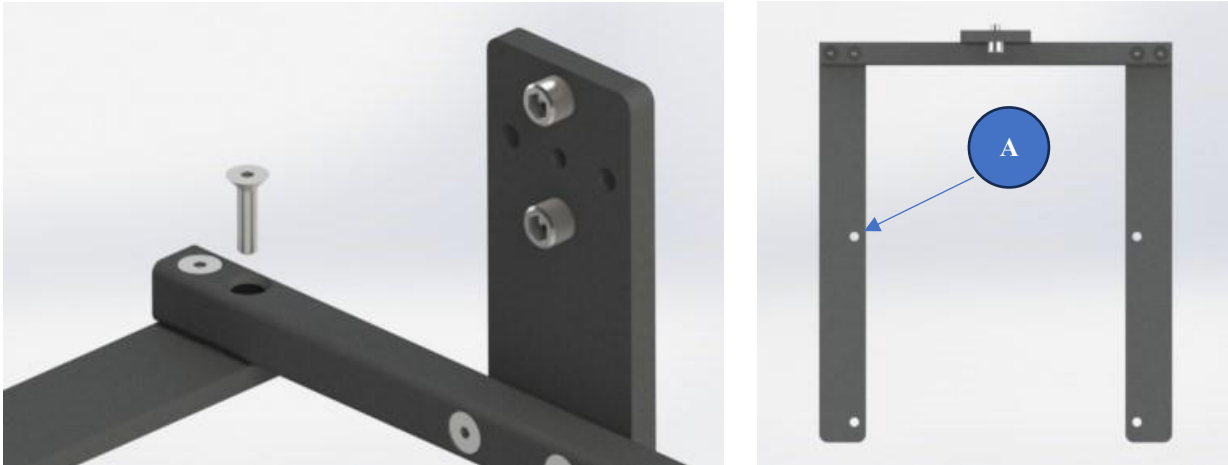

7. Install the leveling pad and jam nut into the center hole in the mounting plate. Adjust so that it protrudes about 1 1/2". Do not tighten the jam nut.



8. Assemble the mounting screws which consist of (2ea.) 7/16-14 x 3 1/2" long socket head cap screws and hardened spherical washers. The hardened spherical washers consist of two mated parts one washer has a concave face that mates with a convex face on the other washer.

This side
Toward
Stand Bolt



This side
Toward
Head



9. Fastening the speaker mount assembly to the upright using the bolts that were prepared in step 6.

The top left image shows the vertical set-up with tilt potential.

The top right image shows the horizontal set-up with tilt potential.

The bottom left image shows the vertical set-up without tilt potential.

The bottom right image shows the vertical set-up from the rear it shows how the mounting bolts pass through the vertical slot in the upright to thread into the holes in the speaker mount assembly.

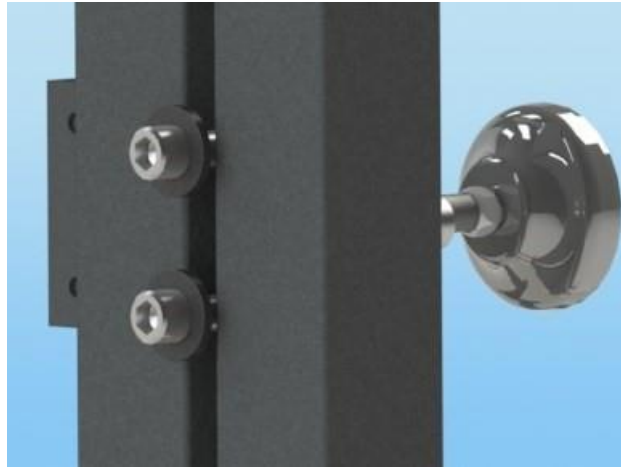
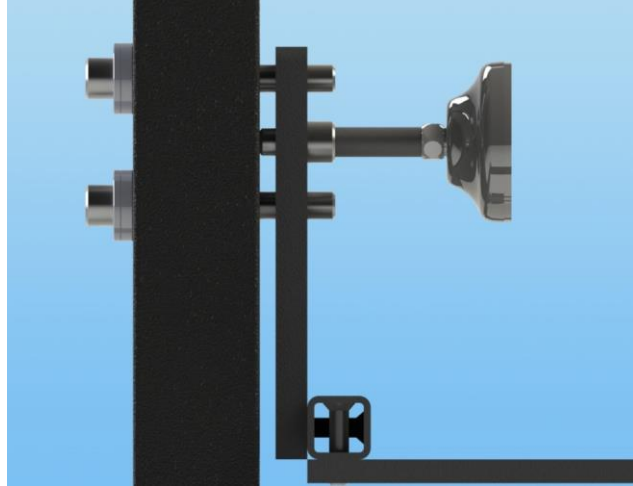
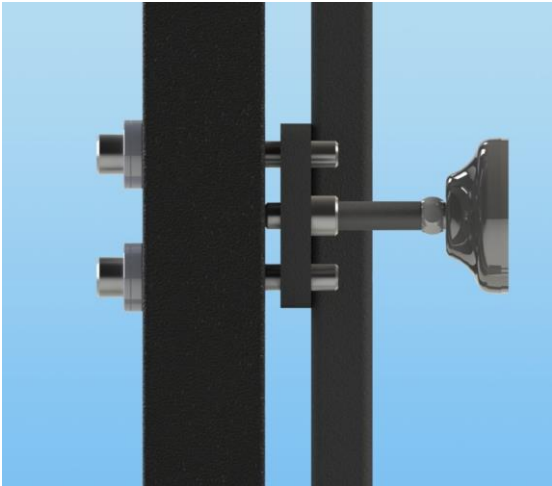

Tilt Adjustment

Initially the mounting bolts are tightened as shown in the above images so that the mount is level. This is a good starting point for tilt adjustment. Final tilt adjustment is the last setup task and is completed after the speaker is mounted and the stand is in its final position behind the desk.

Securing the MM27 to the Stand

CAUTION: Some MM27s came with M8 mounting inserts. Sound Anchors supplies both 5/16-18 and M8 bolts. Test fit to see which inserts your speaker has by inserting a 5/16 bolt with only your fingers (no tools). If the 5/16 bolt does not thread in easily try an M8 bolt. If there is not less than 1/2" between the bolt head and the back of the speaker you will need shorter screws. Shorter screws can be purchased from a good hardware store, or you can contact Sound Anchors. In any case if the bolts do not thread in easily without tools do not force them. Your speakers may be damaged.

Horizontal Setup

1. Remove the handles from the speaker. It is actually only necessary to remove the handles from one side but we like the looks better when both handles removed
2. Place your speaker on the mount assembly so that the inserts that were previously used to fasten handles to the speaker line up with the holes in the speaker mount.
3. See the above caution.
4. Fasten the speaker to the stand using 4 ea. of the appropriate 5/16-18 or M8 bolts with flat washers. Finger tighten only.
5. Tighten the flathead screws that fasten the mounting bars to the mounting tubes.
6. Tighten the speaker mounting screws. Do not over tighten them as this could damage the speaker.
7. Adjust the leveling pad so that it just touches the speaker then tighten 1/4-1/2 turn by hand and lock down the jam nut.

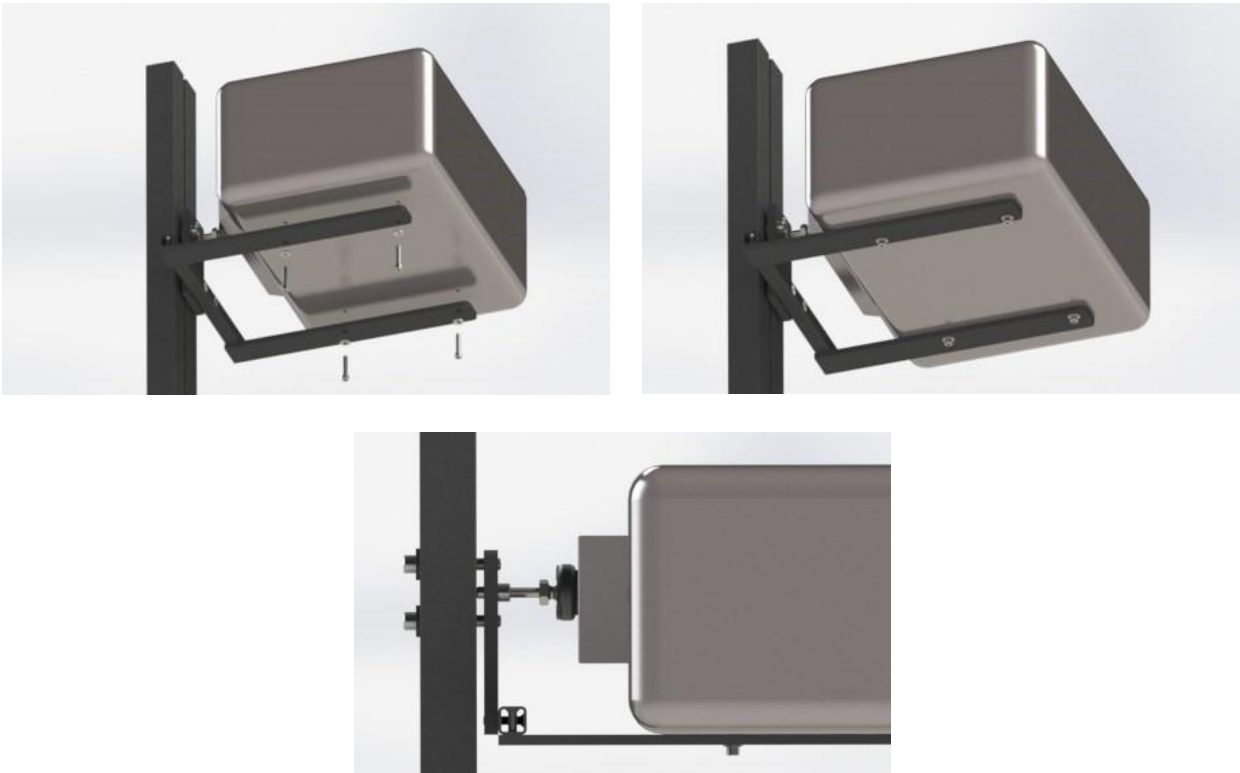

Securing the MM27 to the stand Horizontal.

CAUTION: Some MM27s came with M8 mounting inserts. Sound Anchors supplies both 5/16-18 and M8 bolts. Test fit to see which inserts your speaker has by inserting a 5/16 bolt with only your fingers (no tools). When screwed all the way in there needs to be less than 1/2” between the bolt head and the back of the speaker. If the 5/16 bolt does not thread in easily try an M8 bolt. If there is not less than 1/2” between the bolt head and the back of the speaker you will need shorter bolts. Shorter bolts can be purchased from a good hardware store, or you can contact Sound Anchors. In any case if the bolts do not thread in easily without tools do not force them. Your speakers may be damaged.

VERTICAL SET-UP

1. Remove the handles from the speaker. It is actually only necessary to remove the handles from one side but we like the looks better when all handles removed.
2. Our preferred method requires a small table we have found this to be the easiest and safest method for setting up vertical assembly.
3. Line up your speaker and mount assembly so that the inserts that were previously used to fasten handles to the speaker line up with the holes in the speaker mount.
4. See the above caution.
5. Fasten the speaker to the stand using 4 ea. of the appropriate 5/16-18 or M8 bolts with flat washers. Finger tighten only.
6. Tighten the flathead screws that fasten the mounting bars to the mounting tubes.
7. Tighten the speaker mounting screws. Do not over tighten them as this could damage the speaker.
8. Adjust the leveling pad so that it just touches the speaker then tighten 1/4-1/2 turn by hand and lock down the jam nut.
9. Remove the table.

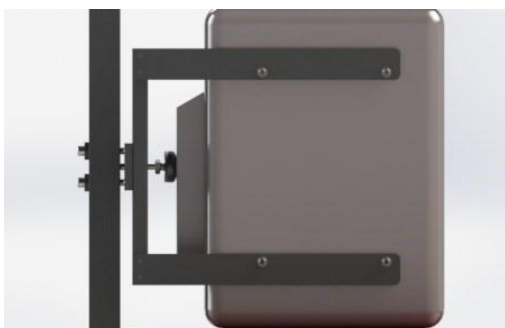

Securing the MM27 to the stand Vertical.

Height Adjustment

The procedure is the same for both horizontal and vertical setups.

1. Loosen the lower of the two mounting bolts.

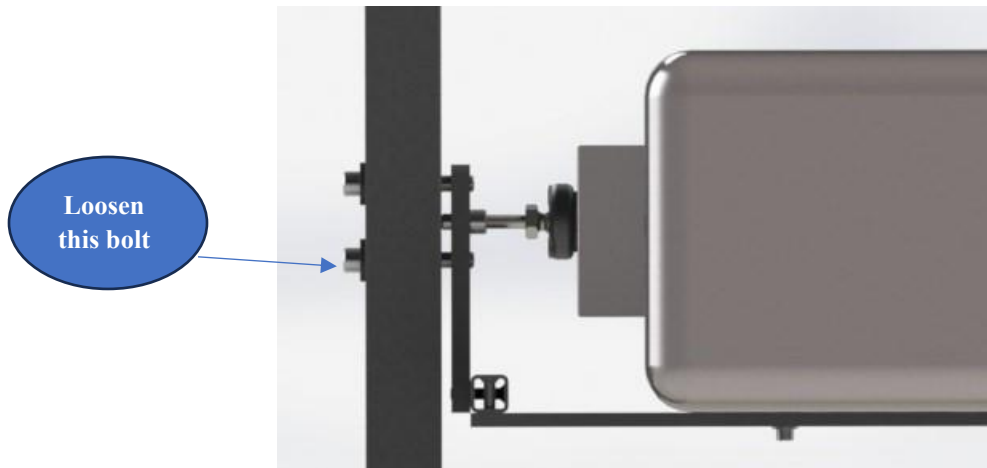

2. Slide the speaker and mount into the desired height position.
3. Tighten the lower bolt to its original tightness.
4. Your height is now rough set you may want to fine tune it again once you get your stands located in their final position.

Leveling System

1. Before you level your stands, you must position them where you will be using them. We recommend that you check the level each time you move your speakers even if only an inch.
2. Leveling the stands is accomplished by threading the spikes in or out. You will want all 4 spikes exerting the same amount of force on the floor.
3. The reference for level is the upright not the base. You will need to position a carpenter's level vertically on the side surface of the upright to adjust side to side level.
4. Repeat this procedure on the rear surface of the upright to adjust front to back level.
5. You may want to repeat this procedure a few times if you want to get your level perfect.
6. Check that all 4 spikes are exerting the same amount of force on the floor and tighten the jam nuts on the spikes.

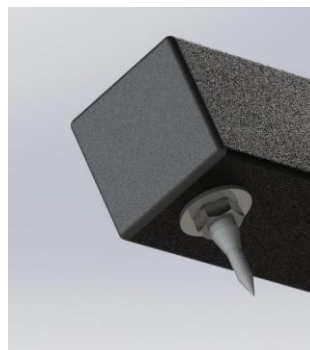

Tilt Adjustment

1. Start by tightening the 7/16-14 mounting bolts so that the speakers are level to the stand
2. If you wish to use the speakers level, snug up the mounting bolts by tightening both bolts the same amount.
3. If you wish to tilt your speakers down loosen the top bolt and tighten the bottom bolt 1/4 turn at a time until the desired speaker tilt is achieved.
4. After setting tilt tighten both bolts the same amount a little at a time until the bolts are tight.
5. If you wish to tilt your speakers up loosen the bottom bolt and tighten the top bolt 1/2 turn at a time until the desired speaker tilt is achieved.
6. After setting tilt tighten both bolts the same amount a little at a time until the bolts are tight.



Important Black & Blue Dot Guidelines

Sound Anchors' Black & Blue Dots are made of urethane coated Sorbothane. Sorbothane is unique in that it absorbs motion in all directions making it an ideal isolation material between speakers and stands. Black & Blue Dots do not have adhesive on them. The blue side should be placed on the stand and the black side should be placed under the speaker. However, under the weight of the speaker and over time they will compress and become gummy and possibly discolor or mar the finish on the bottom of the speaker. Under certain conditions they may also adhere to the bottom of your speakers, causing difficulty in removing or repositioning the speaker. The urethane coating has been added to help alleviate this issue.

Care should be used when removing speakers from the stands as to avoid damaging the bottom of the speaker. It is recommended that a thin blade (i.e. putty knife) be slid in between the speaker and the platform to break the adhesion and dislodge the Black & Blue Dot. Black & Blue dots should not be used on speakers with a lacquer finish. These surfaces are highly susceptible to marring from use of the Black & Blue dots.