

SOUND ANCHORS LARGE ADJUSTABLE MONITOR STAND INSTRUCTIONS



SOUND ANCHORS INCORPORATED

2823 KIRBY CIRCLE NE. unit 110

PALM BAY, FLORIDA 32905 USA

Phone: (321) 724 1237 Fax: (321) 914 0953

www.soundanchors.com

info@soundanchors.com

Thank you for selecting Sound Anchor Large Adjustable monitor stands to support your studio monitors. Designed with the recording industry in mind, our stands offer unbeatable stability, height adjustability, isolation, and durability. Our unique isolation design ensures that any unwanted vibrations or resonance are minimized, providing you with the cleanest sound possible. We know that you will find these stands to be an indispensable fixture in your recording studio.

Please check this inventory list against the drawing on the following page. We chose common fasteners wherever possible, most can be easily obtained from your local hardware store. The part list below has complete fastener specifications. If there are any parts missing, please let us know.

INVENTORY LIST

ITEM NO.	PART DESCRIPTION	QTY.
1	FOOT	2
2	TOP WELDMENT	1
3	UPRIGHT WELDMENT	2
4	BOTTOM WELDMENT	1
5	SUPPORT BAR	4
6	3/8-16 x 1/2 SOCKET HEAD CAP SCREW	8
7	7/16-14 x 3 1/2 SOCKET HEAD CAP SCREW	4
8	7/16-14 x 2 1/2 SOCKET HEAD CAP SCREW	4
9	5/16-18x 3/4 SOCKET HEAD CAP SCREW	8
10	5/16-18 x 1/2 SOCKET HEAD CAP SCREW	4
11	7/16 SAE FLAT WASHER	8
12	7/16-14 x 3/4HEX HEAD CAP SCREW	8
13	3/8-16 HEX JAM NUT	8
14	7/16-14 HEX JAM NUT	4
15	3/8-16 SPIKE	8
16	3/8 ID SAE. FLATWASHER	8
17	7/16 ID. HARDENED BLACK WASHER	8
18	BLACK END CAP 1 1/2 x 3	8
19	BLACK END CAP 2 x 2	8
20	BLACK & BLUE DOTS	8
21	3/8 HEX KEY	1
22	1/4 HEX KEY	1
23	3/16 HEX KEY	1

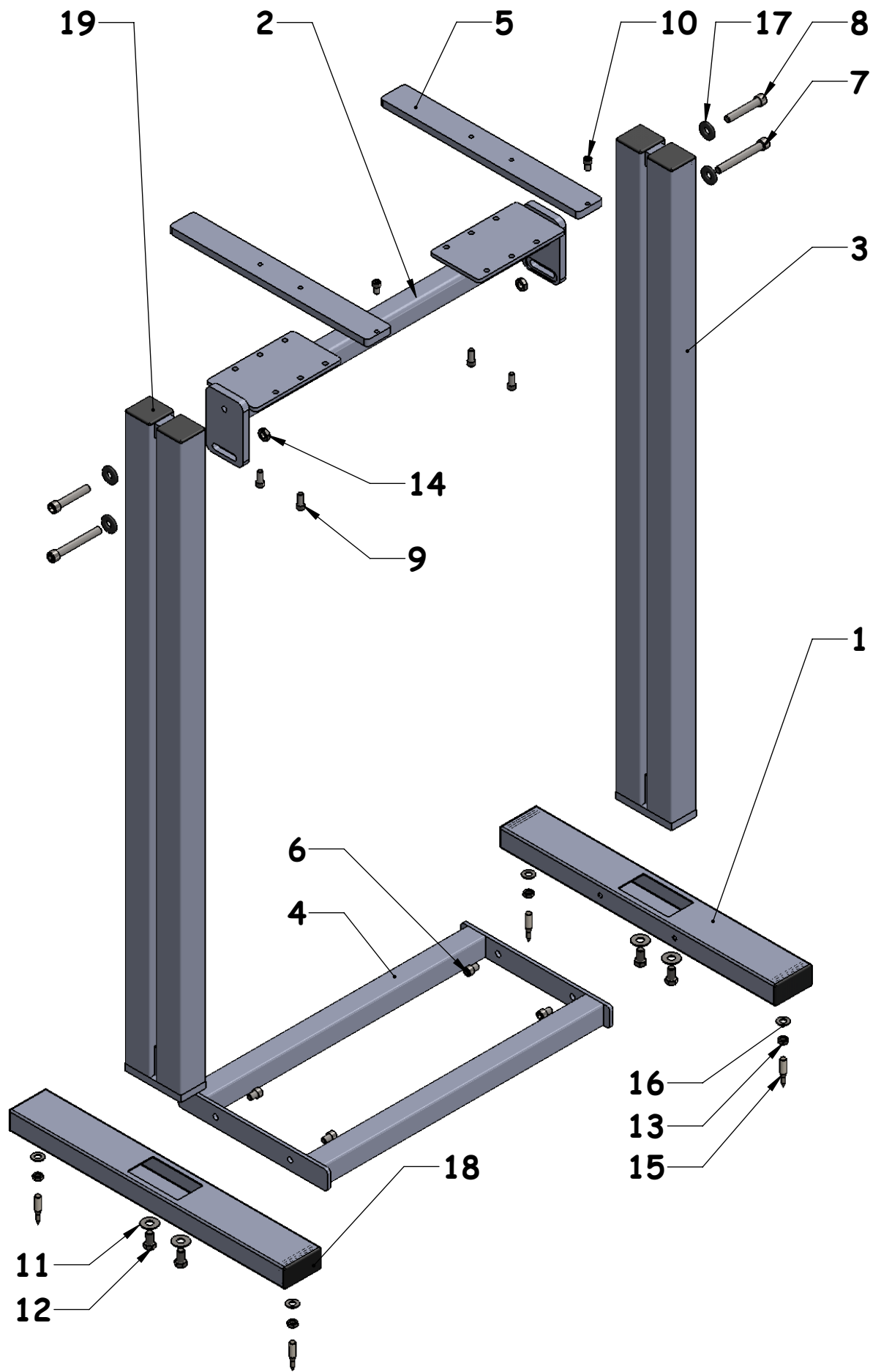

Assembling the Uprights

1. Insert the end of one of the uprights into the rectangular opening in the top of the foot.
2. Use 2 each 7/16-14 hex head cap screws with washers to fasten the upright to the foot.
3. Tighten the cap screws with a 5/8 inch wrench .
4. Repeat this operation until all of your uprights are assembled.

Assembling the Speaker Support

1. Insert 1 each 5/16-18 x 1/2 socket head cap screw into the end of each speaker support bar.
2. Attach 2 support bars to each top weldment using 5/16-18 x 3/4 socket head cap screws. Take care that the socket head cap screws that you inserted in step one are both facing upward.
3. Depending on the width of your speakers we may have provided you with more than one set of mounting holes for your speaker support bars. The holes that you choose are your option. The holes that you choose will depend on your setup.

Putting It All Together

1. Fasten the bottom weldment to the upright assembly using 3/8-16 x 1/2 socket head cap screws.
2. Mount the speaker support assembly to the upright by inserting a 7/16-14 x 2 1/2 socket head cap screw and hardened washer through the slot in the one of the upright sand into the threaded hole in the end of the speaker support assembly. Choose a spot near the top of the stand.
3. Lay the stand down on its side with the side with the speaker support assembly toward the floor.
4. Fasten the other end of the speaker support assembly to the other upright by inserting a 7/16-14 socket head cap screw and hardened washer through the slot in the upright into the threaded hole in the and of the speaker support assembly. Snug up this bolt.
5. Install spikes 3/8" washers and 3/8-16 Jam nuts as shown in fig. 1 if using the optional short black spikes and conecoasters see fig.2

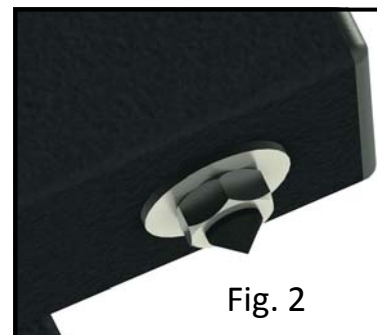
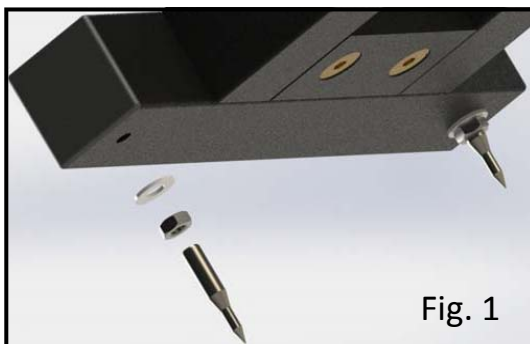

Important!

Make certain all spikes and screws are installed before filling the stands because the filler material will escape if they are not!

If you are going to be filling your stands this is the time to do it. You may use any loose material to fill your stands (sand, pea gravel or kitty litter are commonly used). We have been getting the best results using medium grit silica or general purpose construction sand. This sand is available at some of the larger hardware stores and most home improvement stores such as Lowes, Home Depot, etc.

Place the stand in a position close to a where it will be used.

After you have determined the final position for your stands you will need to level the system using in the spikes at the floor. When everything is adjusted properly, lock down the jam nuts.

Repeat steps one through 10 on the second stand.

Place four Black & Blue dots on each of your stand platforms. Remove the plastic film from the blue side and place the blue side on the platform. The speaker should rest on the black side of the Sorbothane pad. You may now place your speakers on your stands.

The height and angle of your speakers can be adjusted anytime by carefully loosening the 7/16-14 socket screw and sliding the platform up or down in the stand. When doing this make certain that you do not loosen the platform too much.

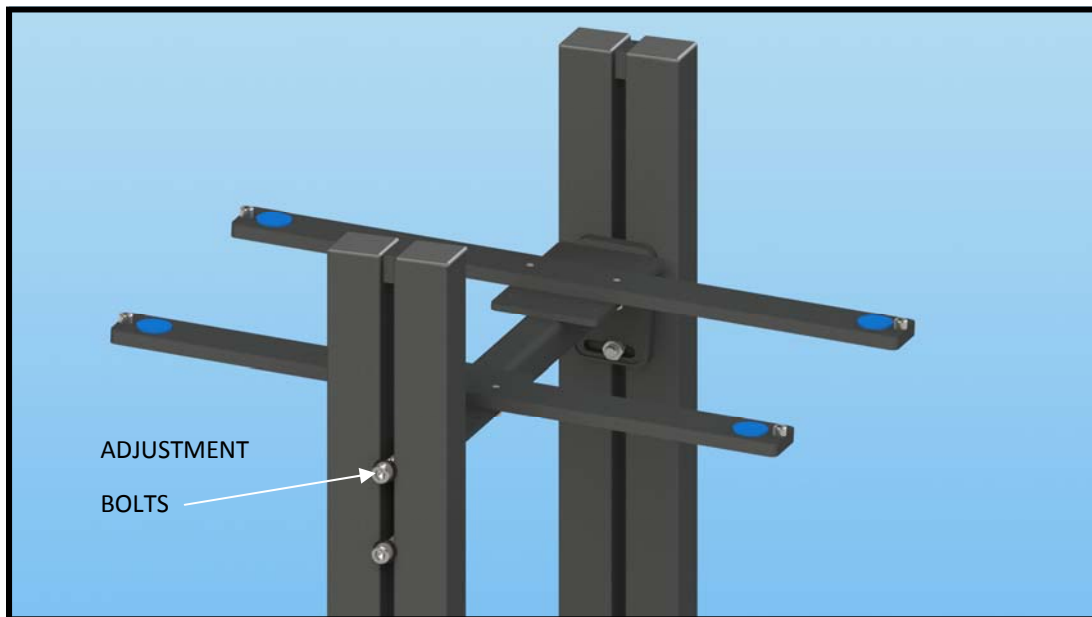

Important Blue Dot Guidelines

Sound Anchors' Blue Dots are made of Sorbothane. Sorbothane is unique in that it absorbs motion in all directions making it an ideal isolation material between speakers and stands. Blue Dots do not have adhesive on them. However, under the weight of the speaker and over time they will compress and become gummy and possibly discolor or mar the finish on the bottom of the speaker. Under certain conditions they may also adhere to the bottom of your speakers, causing difficulty in removing or repositioning the speaker. Care should be used when removing speakers from the stands as to avoid damaging the bottom of the speaker. It is recommended that a thin blade (i.e. plastic putty knife) be slid in between the speaker and the platform to break the adhesion and dislodge the blue dot. Blue dots should not be used on speakers with a lacquer finish. These surfaces are highly susceptible to marring from use of the blue dots.



Sound Anchors®

SOUND ANCHORS

Studio Solutions

ADJ1 & ADJ2

Adjustable stands designed to support near field monitors above the meter bridge.

- Adjustable height & tilt
- 44" or 56" uprights
- ADJ1 base is 14" x 17"
- ADJ2 base is 17" x 24"



ADMID

Large adjustable stands designed to support larger midfield and main monitors where they sound the best

- Adjustable height
- 46" or 56" uprights
- Adjustable tilt
- Cust. width to match monitor

ADJ3

Adjustable stands designed to support 2 near field monitors behind the recording console.

- Adjustable height & tilt
- 44" or 56" uprights
- 23" x 17" base



ADJ4

Adjustable stands designed to support near field monitors above the meter bridge. When there is only 2.75" to 5" between console and the wall.

- 44" or 56" uprights
- Uprights move left / right for best positioning
- Standard base is 17" x 23"

Compact ADJ

Adjustable monitor stand designed for tight spaces between the control surface and the wall.

- Height adjustable, 35" - 42"
- 14" x 10" base
- Ideal for speakers 10" x 10" or smaller

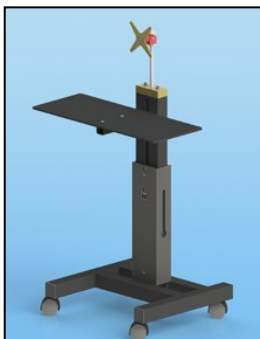

DAW

Digital audio workstation stands are sturdy and durable. Options:

- 1 or 2 monitor supports
- Multiple platforms
- Music keyboard support
- Taller upright for standing applications

Motorized ADJ

Motorized adjustable height stands designed to allow the near field monitors to be hidden when not in use.

- 25.5" of height travel
- Setup as low as 7"
- Max height 51"

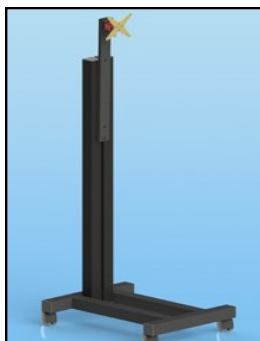

LCD Stand

Designed to support VESA compliant LCD or computer monitors.

- LCD1: 14"x17" base, 44" tall
- LCD2: 17"x23" base, 44" tall
- LCD3: 36"x24" base, 60" or 72" tall
- Floor interface is spikes, casters or leveling pads

Represented in North America By:

TransAmerica Audio Group, Inc.
 7340 Smoke Ranch Road Suite A, Las Vegas, NV 89128
 Phone: 702-365-5155 Fax: 702-365-5145
 Email: sales@transaudiogroup.com

Factory Warranty, Parts and Service:

Sound Anchors
 2835 Kirby Circle NE, Suite 110, Palm Bay, FL. 32905
 Phone: 321-724-1237 Fax: 321-914-0953
 Email: office-2@soundanchors.com