



Sound Anchors ADJ4 Instructions



Sound Anchors
2835 Kirby Cir NE Unit 110
Palm Bay, FL 32905
321-724-1237

Office@Soundanchors.com

www.soundanchors.com

Sound Anchors ADJ4 Adjustable Speaker Stands

Thank you for choosing Sound Anchors stands for your studio. Our speaker stands can play a key role in studio recordings by helping to ensure accurate and precise sound reproduction. Also, by providing a stable and isolated platform for the speakers, our stands can help reduce unwanted resonance and distortion, improve imaging and bass response, and create a cleaner, clearer sound. Please take the time to carefully read these instructions before assembling your stands.



Hardware Inventory:

- 8 ea. 3/8-16 Spikes
- 8 ea. 3/8-16 Jam Nuts
- 8 ea. 3/8 Flat Washers
- 8 ea. Black & Blue Dots
- 6 ea. 7/16-14 x 2.5 Socket Head Cap Screws
- 6 ea. 7/16 Black Hardened Washers
- 4 ea. 1/4-20 x 5/8 Flat Head Cap Screws
- 1 ea. 3/8 Hex Wrench
- 1 ea. 5/32 Hex Wrench

Assembly

1. Fasten the base to the upright using 2 ea. 7/16-14 x 2.5 Socket Head Cap Screws and 2 ea. 7/16 Black Hardened Washers as shown in Figure 1.

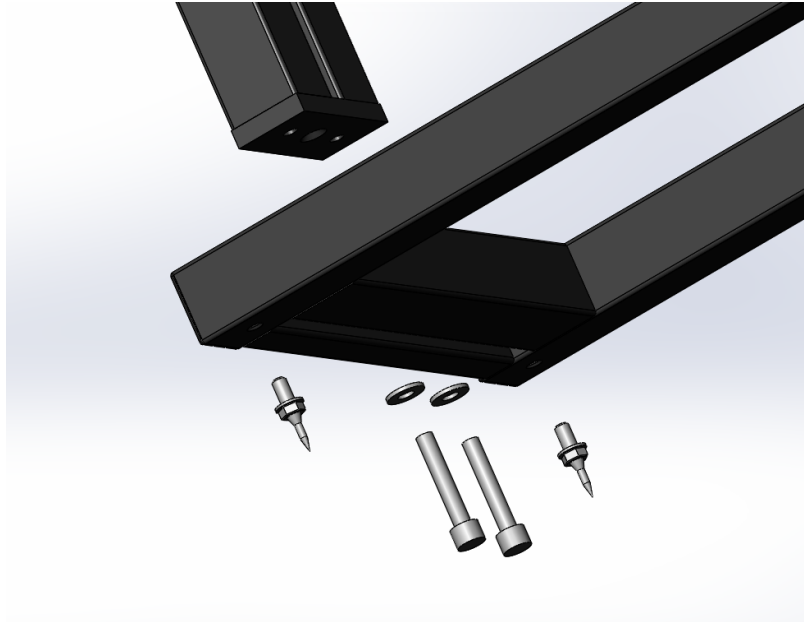

Figure 1

2. Install spikes, washers, and jam nuts into the four threaded holes in the stand's base. Insert the spikes so that there are 1 or 2 spike threads visible after the jam nuts are set. ***Jam nuts should be finger tightened only – no tools.***
3. Mount the "R" Stalk platform assembly to the stands upright. Use 1 ea. 7/16-14 x 2.5 Socket Head Cap Screw and 1 ea. 7/16 Black Hardened Washer as shown in Figure 2.

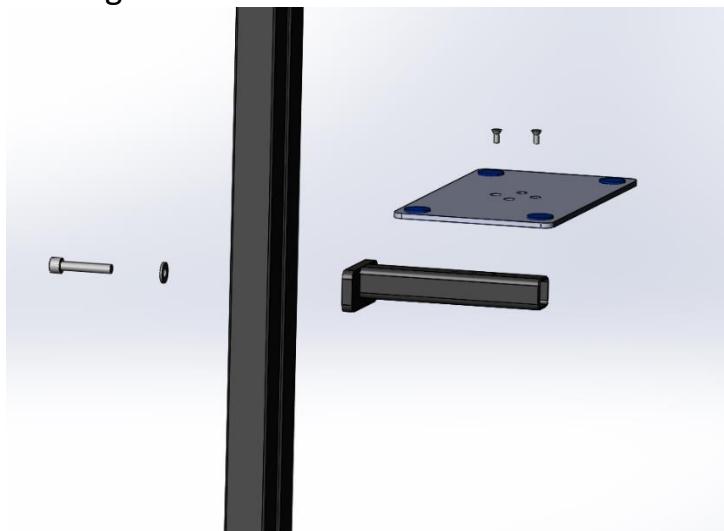

Figure 2

4. After determining the location where you will be setting up your stands, it is time to adjust their level. With the stand in its operational position in the room, place a magnetic torpedo level vertically on the front face of the upright. When the stand is level, tighten the jam nuts with a 9/16 wrench.
5. Adjust the platform to the desired height and tilt. If you will be adjusting the tilt angle of your speakers it is helpful to use a bubble protractor to ensure that each speaker is set up the same when setting up the platform.
6. Remove the protective film from the blue side of the Black & Blue dots. Place the blue side on the platform. The speaker should be placed on the black side of the Sorbothane pad.
7. Place the speaker on the platform so that the front of the speaker extends over the front edge of the platform.

Important Black & Blue Dot Guidelines

Sound Anchors' Black & Blue Dots are made of urethane coated Sorbothane. Sorbothane is unique in that it absorbs motion in all directions making it an ideal isolation material between speakers and stands. Black & Blue Dots do not have adhesive on them. The blue side should be placed on the stand and the black side should be placed under the speaker. However, under the weight of the speaker and over time they will compress and become gummy and possibly discolor or mar the finish on the bottom of the speaker. Under certain conditions they may also adhere to the bottom of your speakers, causing difficulty in removing or repositioning the speaker. The urethane coating has been added to help alleviate this issue.

Care should be used when removing speakers from the stands as to avoid damaging the bottom of the speaker. It is recommended that a thin blade (i.e. putty knife) be slid in between the speaker and the platform to break the adhesion and dislodge the Black & Blue Dot. Black & Blue dots should not be used on speakers with a lacquer finish. These surfaces are highly susceptible to marring from use of the Black & Blue dots.

Sound Anchor ADJ4 Set-Up Options

The Sound Anchor ADJ4 stands are designed for versatility. They feature a more open base design so that the base will fit around table legs or anything else that might make it difficult to properly position your speakers with our ADJ1 or ADJ2 stands. The Upright is 1 1/2 inches further to the rear of the base and it is adjustable side to side. This makes it possible to place speakers closer to rear walls and to make small side to side adjustments.

Offset Right

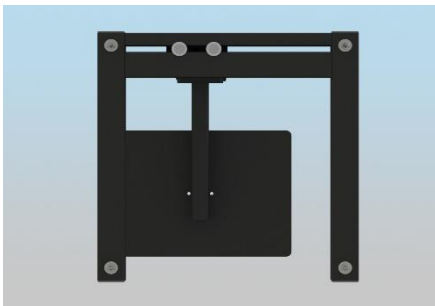

Centered

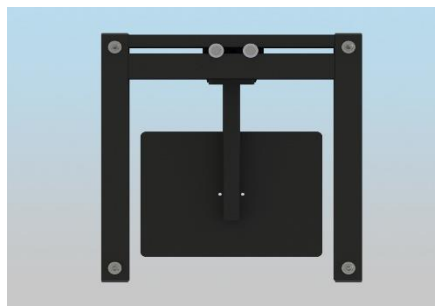

Offset Left

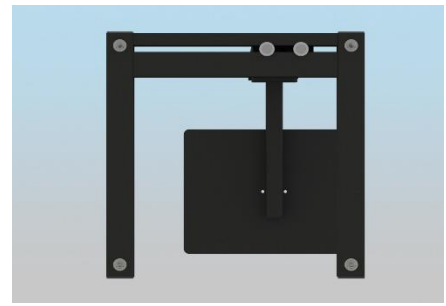

When making side to side adjustments it is important to consider the stability of your system. It is best to position the upright in as close to centered position as possible for your specific application. If it is necessary to offset the upright take care to not set the offset so far left or right that it makes the system unstable. The speaker might need to be offset in relation to the plate to position it toward the center of the base of the stand.